











CE

-  Sollevatore monocolonna
-  Single post jack
-  Einsäulen-Kurzheber
-  Cric monocolonne
-  Elevador monocolumna



-  Comando elettrico con commutatore • Sistema di sollevamento a chiocciola e vite • Chiocciola di sicurezza • Presa ruote con forche intercambiabile
-  Electric drive with reverse-switch • Lifting system by nut and spindle • Safety nut • Interchangeable wheel support bracket
-  Elektroantrieb mit Umschalter • Hubsystem mit Hubmutter und Spindel • Sicherheitsmutter • Radhalterung mit austauschbarer Gabel
-  Actionnement électrique avec commutateur • Système de levage avec écrou et vis • Écrou de sécurité • Fourche prise de la roue interchangeable
-  Mando eléctrico con conmutador • Sistema de elevación con caracol y tornillo • Caracol de seguridad • Horquilla intercambiabile de soporte de ruedas

Dati tecnici	Technical data	Technische Eigenschaften	Caractéristiques techniques	Datos técnicos	
Portata	Capacity	Tragfähigkeit	Capacité	Capacidad de carga	1000 kg
Peso massimo autovettura	Maximal car weight	Max: Fahrzeuggewicht	Poids max. voiture	Peso máximo del vehículo	2000 kg
Altezza massima di sollevamento	Max. lifting height	Max: Hubhöhe	Hauteur max. de levage	Altura máxima de elevación	850 mm
Tempo di salita / discesa	Lifting / Descent time	Hub-/Senkzeit	Temps de levage/descende	Tiempo de elevación / descenso	35 sec
Alimentazione monofase	Single phase power supply	Einphasenmotor	Moteur monophasé	Alimentación monofásica	230/50
Potenza motore	Electric motor power	Motorleistung	Puissance moteur	Potencia motor	0,73 kw
Peso	Weight	Gewicht	Poids	Peso	80 kg
Dimensioni ingombro	Overall dimensions	Abmessungen	Dimensions	Medidas máximas	805 x 660 x 1360 [mm]
Dimensioni ingombro imballo	Overall dimensions packaging	Abmessungen der Verpackung	Dimensions emballage	Medidas máximas embalaje	830 x 770 x 1480 [mm]
Ambiente di lavoro: locale chiuso	Working environment: indoor only	Arbeitsumgebung: geschlossenem Raum	Environment d'utilisation: en local fermé	Entorno de trabajo: local al cubierto	

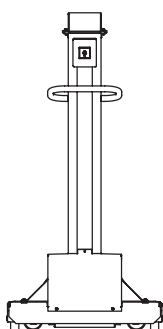
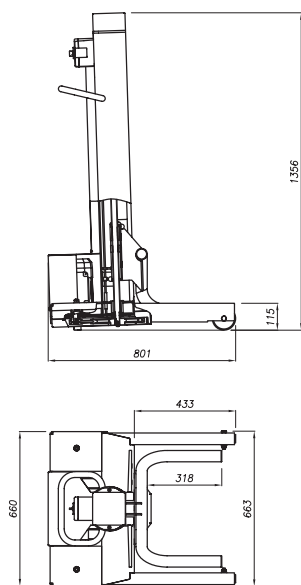

R1_2U/12/07



Opzioni

Optionals

Sonderzubehör

Options

Opcionales



Preso sotto scocca
Underbody support bracket
Unterbodenaufnahme
Prise sous chassis
Prensa bajo bastidor



Tavola di appoggio gommata
Rubber coated support plate
Aufnahmeplatte mit Gummiabdeckung
Plaque de support avec couverture en caoutchouc
Tablero de apoyo engomado



Colonna 800-1200 mm,
1500 kg
**Axle stand 800-1200 mm,
1500 kg**
Chandelle 800-1200 mm,
1500 kg
Unterstellbock
800-1200 mm, 1500 kg
Column 800-1200 mm,
1500 kg

The company reserves the right to introduce improvements in design or specification without prior notice